

Model Answers

Domain	Furniture > Furniture Making			
Unit	14998 v 5	Construct isometric and oblique drawings for use in furniture making	Level 3	Credits 4

Assessment Information

Entry Information

There are no pre-requisite requirements for this unit.

Required Evidence

This Assessment Guide, that includes the following completed assessment tasks:

- » Task sheet
- » Observation Checklist
- » Attach additional evidence

Appeals

The candidate must understand the appeals process before carrying out this assessment.

Information about Competenz's assessment appeals process can be found on the Assessors and Moderators page of Competenz's website www.competenz.org.nz.

Change control

The following changes have been made to Unit Standard 14998 v5 assessment materials.

Edition of this document	Changes made
Edition 1 June 2017	<ul style="list-style-type: none">» Unit standard version 5» Updated to Competenz 2017 assessment templates, including the addition of a 'Candidate evidence check', legislative updates in 'Assessment requirements', and the addition of an 'Assessor final judgement' section.» Updated formatting.» Footer has been updated to reflect new Edition.
Edition 1 Dec 2014	No changes. Original document. Version 4

Assessment Requirements

This Assessment Guide is designed to help you provide evidence of your skills and knowledge required by this unit standard.

People credited with this unit standard are able to: prepare to construct and construct isometric and oblique drawings for use in furniture making; and store isometric and oblique drawings and equipment for use in furniture making.

Before you begin

Read through the assessment requirements yourself. Talk with your Assessor if there is anything you don't understand.

Meet with your Assessor to plan your assessment. Your Assessor will:

- » talk you through this Guide, and discuss when and how you will be assessed.
- » check you are ready to begin this assessment.

What you need to do

1. Complete the following assessment tasks:

Task Sheet	From your job specifications provide: <ul style="list-style-type: none">» a working drawing.» and a written explanation.
Observation Checklist	Be observed constructing isometric and oblique drawings for use in furniture making , it is clear that the candidate can competently: <ul style="list-style-type: none">» Prepare to construct isometric and oblique drawings for use in furniture making.» Construct isometric and oblique drawings for use in furniture making.» Store isometric and oblique drawings and equipment for use in furniture making.» Answering verbal questions on the tasks involved in the assessment.
Additional evidence	<ul style="list-style-type: none">» Attach your isometric drawing according to job specifications.» Attach your oblique drawing according to job specifications.

Note: Your Assessor may choose someone to verify and/or observe your work. This person must have expertise in constructing isometric and oblique drawings for use in furniture making and could be someone you report to, your trainer, or a supervisor or manager who works with you regularly.

2. You may wish to provide additional supporting evidence that proves you have the knowledge and skills required by this unit. Additional evidence may include, for example, workplace documentation you have used and/or completed, training records, photos, screenshots, printouts, videos, voice recordings.
3. When you have completed all assessment tasks, complete the 'Candidate evidence check' at the end of this Guide.

4. When you are sure you have completed and/or attached everything, contact your Assessor or Account Manager to arrange next steps.

Conditions

- » Your evidence must clearly show competence in constructing isometric and oblique drawings for use in furniture making.
- » Drawings may be of items of furniture or furniture components and may include but are not limited to – bedside cabinets, tables, dining chairs, chair legs, table legs, desks, beds.
- » Complete all assessment tasks yourself. Use your own words when answering questions.
- » It is expected that you will have had learning / experience in constructing isometric and oblique drawings for use in furniture making on more than one occasion, before you are formally assessed.
- » It is likely that you will have already been observed in constructing isometric and oblique drawings for use in furniture making on more than one occasion, before you are formally assessed.
- » Your assessment tasks may be in an on-job or off-job environment. However, job specifications, and drawing output must conform to current commercial industry practice.
- » Drawings may be completed by hand or using a computer aided drawing system (CAD).
- » All tasks you carry out for this assessment must be completed following workplace procedures, and comply with organisational and legislative (legal) requirements.

Definitions

- » *Worksite policies and procedures* refer to documented policies and to documented or other directions provided to staff. These may include, but are not limited to, ways of managing health and safety, environmental considerations, quality, and production, and must conform to legislation. Examples include standard operating procedures, company health and safety plans, on-site briefings, and supervisor's instructions. For the purposes of this unit standard worksite policies and procedures may also refer to the policies and procedures of an off-job training site.

Unit Standard Evidence Map

Unit 14998 v 5	Construct isometric and oblique drawings for use in furniture making	Level 3	Credits 4
Explanatory notes:			
<ul style="list-style-type: none"> • This unit standard may be assessed against on-job or off-job. However, job specifications, and drawing output must conform to current commercial industry practice. • Drawings may be of items of furniture or furniture components and may include but are not limited to – bedside cabinets, tables, dining chairs, chair legs, table legs, desks, beds. • Drawings may be completed by hand or using a computer aided drawing system (CAD). 			
Outcomes and Evidence Requirements		Evidence	No.
Outcome 1: Prepare to construct isometric and oblique drawings for use in furniture making.			
1.1	Job specifications are obtained and explained in accordance with worksite policies and procedures. Range working drawing, written description.	Task sheet	1 & 2

1.2	The equipment selected and prepared is in working order and of the quality required to produce the drawings required by job specifications. Range equipment – drawing board, T-square, pencils, erasers, set-squares, scale rule, drawing paper, paper-fastening medium; quality required – undamaged surface of drawing board, clean and clear surface of drawing board, unmarked paper.	Observation Checklist	1-7
1.3	Preparations include attaching the drawing paper to the drawing board in accordance with worksite policies and procedures.	Observation Checklist	8
Outcome 2: Construct isometric and oblique drawings for use in furniture making. Range must include a minimum of one isometric and one oblique drawing.			
2.1	Drawings are set out in accordance with job specifications.	Observation Checklist	9 & 14
2.2	Views are in accordance with job specifications.	Observation Checklist	10 & 15
2.3	Drawings' features are in accordance to job specifications. Range features include – scale, dimensions.	Observation Checklist	11 & 16
2.4	Drawings' quality principles are in accordance with job specifications. Range quality principles include – title block, letter size, dimensioning, line quality.	Observation Checklist	12, 13 & 17, 18
Outcome 3: Store isometric and oblique drawings and equipment for use in furniture making.			
3.1	Drawings are stored in accordance with worksite policies and procedures.	Observation Checklist	19
3.2	Equipment is stored in accordance with worksite policies and procedures.	Observation Checklist	20
3.3	Equipment and work area are made clean, clear, and safe in accordance with worksite policies and procedures.	Observation Checklist	21

Any queries, contact: Competenz, PO Box 9005, Newmarket, Auckland 1149. Ph. 0800 526 1800

Task Sheet

Carefully read through this Task Sheet so you know exactly what is expected.

Complete all tasks in this Task Sheet. You will need to:

- » Create a working drawing of a job specification.'
- » Create a written description of your job specification.

You can answer the questions in writing, or give your answers verbally to your Assessor who will write down what you say. You may need to arrange this in advance with your Assessor.

Your Assessor may ask you additional questions to check your knowledge and understanding.

Assessor

This Task Sheet supports E.R. 1.1.

Judgement statements

The completed Task Sheet supports the candidate's successful performance in

- Obtaining and explaining job specifications in accordance with worksite policies and procedures.
- Providing a working drawing and a written description of the job specification.
- The candidate's written and/or verbal responses support their competency in the tasks.

Your name	Candidate name provided
Workplace	Workplace identified
Date	Date recorded

Using the job specification you will work from to construct isometric and oblique drawings for use in furniture making

1. Provide a working drawing of the job specification and if required give a verbal explanation to your assessor:

Assessor

This question supports E.R. 1.1.

Judgement statement

- The candidate provides a working drawing of the job specification.
- Answers are in accordance with worksite policies and procedures.

Example answer

Answers will vary according to job specification.

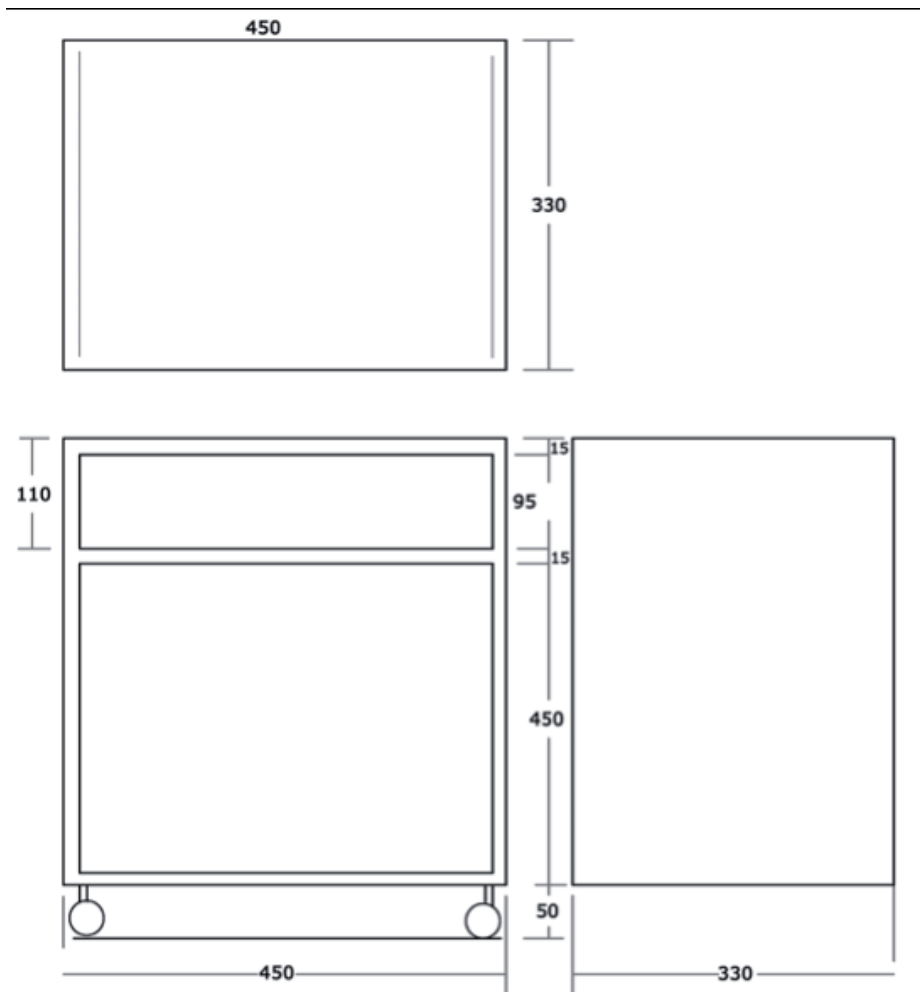

2. Provide a written description of the job specification and if required give a verbal explanation to your assessor:



Assessor

This question supports E.R. 1.1.

Judgement statements

- The candidate provides a written explanation of the job specification.
- Answers are in accordance with worksite policies and procedures.

Example answer

The dimensions of the cabinet are 575mm high, width and 330mm deep.

You have reached the end of the Task Sheet.

Observation Checklist

Carefully read through this Observation Checklist so you know exactly what is expected.

You, the candidate, must fill in Part A.

Part B will be completed by your Assessor or someone who has been approved by your Assessor.

You must be observed **constructing isometric and oblique drawings for use in furniture making**. This will involve:

- » Preparing to construct isometric and oblique drawings for use in furniture making.
- » Constructing isometric and oblique drawings for use in furniture making.
- » Storing isometric and oblique drawings and equipment for use in furniture making.
- » Attaching workplace documentation relevant to the assessment task.

You may need to be observed more than once.

Your Observer may ask you additional questions to check your knowledge and understanding.

Note to the Observer

- » Complete Part B of this checklist.
- » Watch the candidate carry out each task.
- » Note down any extra questions you ask of the candidate during the observation, and their response.
- » Make sure the candidate has attached workplace documentation relevant to the assessment task.

Assessor

This Observation Checklist supports the candidate's successful performance in constructing isometric and oblique drawings for use in furniture making.

Judgement statements

- The candidate has prepared to construct isometric and oblique drawings for use in furniture making
- The candidate has constructed isometric and oblique drawings for use in furniture making
- The candidate stored isometric and oblique drawings and equipment for use in furniture making
- The attached workplace documentation supports the candidate's competency in constructing isometric and oblique drawings for use in furniture making.

Part A: Candidate to complete this section

Your name Candidate name provided

Workplace Workplace identified

Part B: Observer to complete this section

For each statement below, tick if you agree.

When preparing to construct isometric and oblique drawings for use in furniture making, the candidate:

1. Selects and checks the drawing board is clean, clear and the surface undamaged.

2. Selects a T-square appropriate for the size of the drawing board.

3. Selects the correct grade of pencils and ensures they are sharp.

4. Selects appropriate erasers.

5. Selects set squares.

6. Selects scale rule,

7. Selects unmarked drawing paper of correct size and appropriate paper-fastening medium.

8. Attaches drawing paper to the drawing board in accordance with worksite policies and procedures.

When constructing isometric drawings according to job specifications, the candidate:

9. Sets out isometric drawing correctly

10. Provides correct views

11. Includes drawing features of scale and dimensions

12. Includes drawings' quality principles, such as:

Title block

Letter size

Dimensioning

Line quality

13. Produces and attaches to the Assessment Guide one isometric drawing

When constructing oblique drawings according to job specifications, the candidate:

14.	Sets out oblique drawings correctly	<input checked="" type="checkbox"/>	
15.	Provides correct views	<input checked="" type="checkbox"/>	
16.	Includes drawing features of scale and dimensions	<input checked="" type="checkbox"/>	
17.	Includes drawings' quality principles, such as:	<input checked="" type="checkbox"/>	
	<input type="checkbox"/> Title block	<input type="checkbox"/> Letter size	
	<input type="checkbox"/> Dimensioning	<input type="checkbox"/> Line quality	
18.	Produces and attaches to the Assessment Guide one oblique drawing	<input checked="" type="checkbox"/>	
When storing isometric and oblique drawings and equipment, the candidate:		<input checked="" type="checkbox"/>	
19.	Stores drawings correctly according to worksite policies and procedures.	<input checked="" type="checkbox"/>	
20.	Stores equipment correctly according to worksite policies and procedures.	<input checked="" type="checkbox"/>	
21.	Makes sure equipment and work area are:	<input checked="" type="checkbox"/>	
	<input type="checkbox"/> Clean		
	<input type="checkbox"/> Safe		
	<input type="checkbox"/> Clear		
Please comment on the candidate's ability to construct isometric and oblique drawings for use in furniture making.			
Any comments support the candidate's successful performance in meeting the above standards.			
I confirm that I have directly observed the candidate carry out all the above tasks to the standard required.		<input checked="" type="checkbox"/> Yes <input type="checkbox"/> No	
I confirm that I have experience in constructing isometric and oblique drawings for use in furniture making.		<input checked="" type="checkbox"/> Yes <input type="checkbox"/> No	
Observer name and title	Observer name and title recorded	Signature	Observer signed
Phone / Email	Contact details recorded	Date	Date recorded

You have reached the end of the Observation Checklist.

Candidate evidence check

Required evidence

Use this checklist to make sure you finished the assessment tasks in full.

Clearly name and label all attachments.

I have completed and/or attached:

- One Observation Checklist completed and signed by an observer
- A working drawing of the job specification
- A written explanation of the job specification
- One isometric drawing
- One oblique drawing.

Assessor

The required evidence for each assessment has been completed and/or attached.

Additional supporting evidence

If you have any other evidence which helps prove your skills and knowledge in this unit (such as completed documents, photos, videos or voice recordings), attach it and record it below.

Clearly name and label all attachments.

I have attached the following as additional supporting evidence:

Assessor

There is no requirement to attach additional supporting evidence.

Any additional supporting evidence is relevant and further supports the candidate's competency in this unit.

Assessor final judgement

After reviewing the candidate's evidence for Unit Standard 14998 v5 **Construct isometric and oblique drawings for use in furniture making**, it is clear that the candidate can competently:

- Prepare to construct isometric and oblique drawings for use in furniture making.
- Construct isometric and oblique drawings for use in furniture making.
- Store isometric and oblique drawings and equipment for use in furniture making.

Assessor feedback to the candidate

Please provide specific feedback to the candidate about their performance in meeting the requirements of this unit standard.

Assessor

Assessor name recorded

Date

Date recorded