

Model Answers

Domain

Furniture Making

Unit

18917 v2

Construct hand joints for furniture

Level 2

Credits 3

Assessment Information

Entry Information

There are no pre-requisite requirements for this unit.

Required Evidence

This Assessment Guide, that includes the following completed assessment tasks:

- » Questions
- » Observation Checklist

Appeals

The candidate must understand the appeals process before carrying out this assessment.

Information about Competenz's assessment appeals process can be found on the Assessors and Moderators page of Competenz's website www.competenz.org.nz.

Change control

The following changes have been made to unit 18917 v2 assessment materials.

Edition of this document	Changes made
Edition 4 August 2017	» Updated to Competenz 2017 assessment templates, including the addition of a 'Candidate evidence check', legislative updates in 'Assessment requirements', and the addition of an 'Assessor final judgement' section. » Updated formatting. » Footer has been updated to reflect new Edition.
Edition 3 January 2017	No changes. Original document.

Assessment Requirements

This Assessment Guide is designed to help you provide evidence of your skills and knowledge required by this unit standard.

Before you begin

Read through the assessment requirements yourself. Talk with your Assessor if there is anything you don't understand.

Meet with your Assessor to plan your assessment. Your Assessor will:

- » talk you through this Guide, and discuss when and how you will be assessed.
- » check you are ready to begin this assessment.

What you need to do

1. Complete the following assessment tasks:

Questions	Answer questions about constructing hand joints for furniture.
Observation Checklist	Be observed on-job or off-job. This will involve: <ul style="list-style-type: none">» preparing to construct hand joints for furniture» constructing hand joints for furniture.

Note: Your Assessor may choose someone to verify and/or observe your work. This person must have expertise in constructing hand joints for furniture and could be someone you report to, your trainer, or a supervisor or manager who works with you regularly.

2. You may wish to provide additional supporting evidence that proves you have the knowledge and skills required by this unit. Additional evidence may include, for example, workplace documentation you have used and/or completed, training records, photos, screenshots, printouts, videos, voice recordings.
3. When you have completed all assessment tasks, complete the 'Candidate evidence check' at the end of this Guide.
4. When you are sure you have completed and/or attached everything, contact your Assessor or Account Manager to arrange next steps.

Conditions

- » Your evidence must clearly show your ability to construct hand joints for furniture.
- » Competence must be demonstrated on a minimum of three of the following hand joints – through dovetail, lapped dovetail, housing, stopped housing, mortise and tenon, bridle, halving, mitre.
- » Personal protective equipment, appropriate to job requirements, is to be selected and used in accordance with worksite policies and procedures and manufacturer's instructions.
- » Complete all assessment tasks yourself. Use your own words when answering questions.
- » This is a closed book assessment. You must complete it without looking at any training material.
- » It is expected that you will have had learning / experience of constructing hand joints for furniture on more than one occasion, before you are formally assessed.
- » It is likely that you will have already been observed on-job or off-job on more than one occasion, before you are formally assessed.
- » All tasks you carry out for this assessment must be completed following workplace procedures, and comply with organisational and legislative (legal) requirements.

Definitions

- » *Manufacturer's instructions* are instructions provided by manufacturers of substances, equipment, and machinery used in furniture making. These instructions may include details on safe and correct handling, use and storage of substances and/or details on substance properties. Examples are labels on substance containers, product data sheets, and operator's manuals.
- » *Worksite policies and procedures* refer to documented policies and to documented or other directions provided to staff. These may include, but are not limited to, ways of managing health and safety, environmental considerations, quality, and production, and must conform to legislation. Examples include standard operating procedures, company health and safety plans, on-site briefings, and supervisor's instructions. For the purposes of this unit standard worksite policies and procedures may also refer to the policies and procedures of an off-job training site.

Unit Standard Evidence Map

Unit 18917 v2	Construct Hand Joints for Furniture	Level 2	Credits 3
Outcomes and Evidence Requirements		Evidence	No.
Outcome 1: Prepare to construct hand joints for furniture.			
1.1	Job specifications are obtained and explained in accordance with worksite policies and procedures. Range: drawings, material, dimensions, type of hand joint.	Questions	1
1.2	Material is selected in accordance with job specifications.	Observation Checklist	2-4
1.3	Hand tools and equipment for the job are selected in accordance with job specifications.	Observation Checklist	2-4
1.4	Three types of hand joints are sketched and explained in terms of their use.	Questions	2
1.5	Environmental and safety requirements are met in accordance with worksite policies and procedures.	Observation Checklist	2-4
Outcome 2: Construct hand joints for furniture.			
2.1	Timber is laid out and marked in accordance with job specifications. Range: face mark, edge mark.	Observation Checklist	5-10
2.2	Joints are marked onto the timber in accordance with job specifications.	Observation Checklist	5-10
2.3	Hand joints are cut in accordance with job specifications.	Observation Checklist	5-10
2.4	Hand joints are fitted together to meet quality requirements in accordance with job specifications. Range: dimension, tolerance, firm fit.	Observation Checklist	5-10
2.5	Work area is made clean, clear, and safe in accordance with worksite policies and procedures.	Observation Checklist	5-10

Any queries, contact: Competenz, PO Box 9005, Newmarket, Auckland 1149. Ph. 0800 526 1800

Questions

Answer the following questions about constructing hand joints for furniture.

Use your own words. You can answer the questions in writing, or give your answers verbally to your Assessor who will write down what you say. You may need to arrange this in advance with your Assessor.

Draw pictures or diagrams to support your answers if you wish.

Your Assessor may ask you additional questions to check your knowledge and understanding.

Judgement statements

- The candidate's written and/or verbal responses support their competency.

Your name	
Workplace	
Answers written by: (Tick one)	<input type="checkbox"/> Candidate <input type="checkbox"/> Assessor <input type="checkbox"/> Other (please write):



1. From the job specification provided by your supervisor/ assessor explain the following requirements.

Assessor

This question supports E.R. 1.1.

To meet the requirements of the standard, there must be at least three of the following hand joints included in the job specification.

Through dovetail, lapped dovetail, housing, stopped housing, mortise and tenon, bridle, halving, mitre.

Example Job Specification

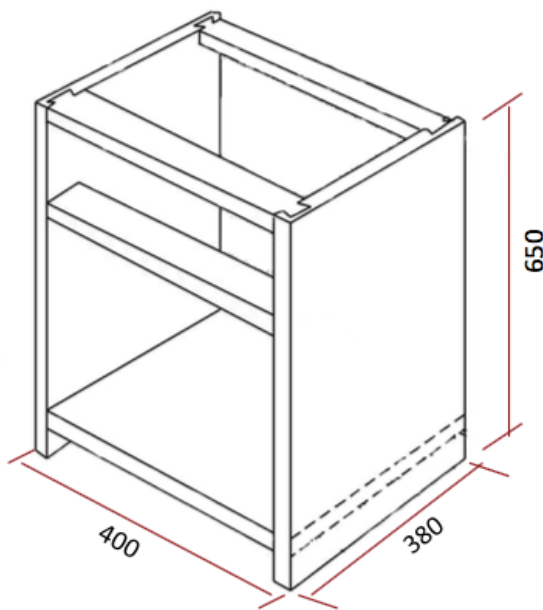

Furniture Carcass

Carcase bottom - Stopped housing joint

Back and front rails - Lapped dovetail joint

Drawer rail - Mortise and tenon joint

Example answer

Requirement	Explanation
Supply an explanation of the drawing	Bedside cabinet carcass
Identify the material/s to be used	Pine
Identify the dimensions of the object	Height = 650mm Width = 400mm Depth = 380mm
Identify all the hand joints	Lapped Dovetail joint

required to be constructed	Stopped housing joint Mortise and tenon
-----------------------------------	--

2. Choose three joints from the hand joints listed below; add them to the table as Joints 1, 2 and 3. Draw a sketch and explain a common use for each joint in the table.

Hand joints: Through dovetail, lapped dovetail, housing, stopped housing, mortise and tenon, bridle, halving, mitre.

Assessor

This question supports E.R. 1.4.

Example answer

Joint	Sketch	Use
1. Lapped Dovetail Joint		This type of joint is sometimes used as the joint for book cases and cabinets. . The joint is very strong as are all dovetail joints.
2. Mortise and Tenon		These are used when making tables or cabinets and they are very strong when glued together
3. Stopped Housing Joint		Found in internal cabinets & joinery, such as shelves, partitions, divisions, stairs and cabinet framework, where the edge appearance is not critical

You have reached the end of the questions.

Observation Checklist

Carefully read through this Observation Checklist so you know exactly what is expected.

You, the candidate, must fill in Part A.

Part B will be completed by your Assessor or someone who has been approved by your Assessor.

You must be observed on-job or off-job. This will involve:

- » preparing to construct hand joints for furniture
- » constructing, hand joints for furniture.

You may need to be observed more than once.

Your Observer may ask you additional questions to check your knowledge and understanding.

Note to the Observer

- » Complete Part B of this checklist.
- » Watch the candidate carry out each task.
- » Note down any extra questions you ask of the candidate during the observation, and their response.

Judgement statements

- The completed Observation Checklist supports the candidate's successful performance in constructing hand joints for furniture.

Part A: Candidate to complete this section

Your name Candidate name provided

Workplace Workplace identified

Part B: Observer to complete this section

For each statement below, tick if you agree.

When demonstrating correct selection of PPE, the candidate ensures that:

1. Personal protective equipment appropriate to job requirements is selected and used.

When selecting materials and tools, the candidate ensures that:

Assessor

[This Observation Checklist supports E.R. 1.2, 1.3, 1.5.](#)

2. Material is selected according to job specifications

3. Hand tools and equipment for the job are selected according to job specifications

4. Environmental and safety requirements are met according to relevant regulations and worksite policies and procedures

When constructing hand joints for furniture, the candidate ensures that:

Assessor

[This Observation Checklist supports E.R. 2.1, 2.2, 2.3, 2.4, 2.5.](#)

5. Timber is laid out and marked according to job specifications:
 Correct placement of face marks
 Correct placement of edge marks

6. Joints are marked onto the timber according to job specifications

7. All hand joints are cut according to job specifications

8. Hand joints are fitted together to meet quality requirements: Quality requirements include:
 Dimensional requirements
 Tolerance requirements
 A firm fit

9. Competence is demonstrated for at least three of the following joints:

- through dovetail
- lapped dovetail
- housing
- stopped housing
- mortise and tenon
- bridle
- halving
- mitre

10. Work area is made:

- Clean
- Clear
- Safe

Please comment on the candidate's ability to construct hand joints for furniture.

Any comments support the candidate's successful performance in meeting the above standards.

I confirm that I have directly observed the candidate carry out all the above tasks to the standard required. Yes
 No

Observer name and title	Observer name and title recorded	Signature	Observer signed
Phone / Email	Contact details recorded	Date	Date recorded

Candidate evidence check

Required evidence

Use this checklist to make sure you finished the assessment tasks in full.

Clearly name and label all attachments.

I have completed and/or attached:

- The Questions in this guide
- One** Observation Checklist completed and signed by an observer.

Assessor

The required evidence for each assessment has been completed and/or attached.

Additional supporting evidence

If you have any other evidence which helps prove your skills and knowledge in this unit (such as completed documents, photos, videos or voice recordings), attach it and record it below.

Clearly name and label all attachments.

I have attached the following as additional supporting evidence:

Assessor

Any additional supporting evidence is relevant and further supports the candidate's competency in this unit.

Assessor final judgement

After reviewing the candidate's evidence for Unit Standard 18917 v2, it is clear that the candidate can competently:

- Prepare to construct hand joints for furniture.
- Construct hand joints for furniture.

Assessor feedback to the candidate

Please provide specific feedback to the candidate about their performance in meeting the requirements of this unit standard.

Assessor

Assessor name recorded

Date

Date recorded